

- Low Cost
- Handles 25 lb. to 140 lb. Open-mouth Paper or Textile Bags
- Automatic Cutoff - No Trimming
- Consistently High Accuracies
- Portable - Easily Attached to any Spout
- Low Headroom

Construction Features

Weight Indicator — includes graduated numeral plate and dash pot to dampen pointer oscillations.

All-Mechanical Operation — no delicate parts or adjustments.

Simple Bag Tare Device — tares out empty bag weight; consists of a movable weight, offset and threaded to provide positive positioning.

Reinforced Oval Bag Spout — heavy plate construction prevents pressure of bagholder cams.

Quick-Attachment Slides — easy to slide on and off when several spouts must be served.

Flow Control Inlet Gate — adjustable for optimum flow of different materials.

"True-Scale" Weigh Beam — 5:1 ratio with calibrated weights.

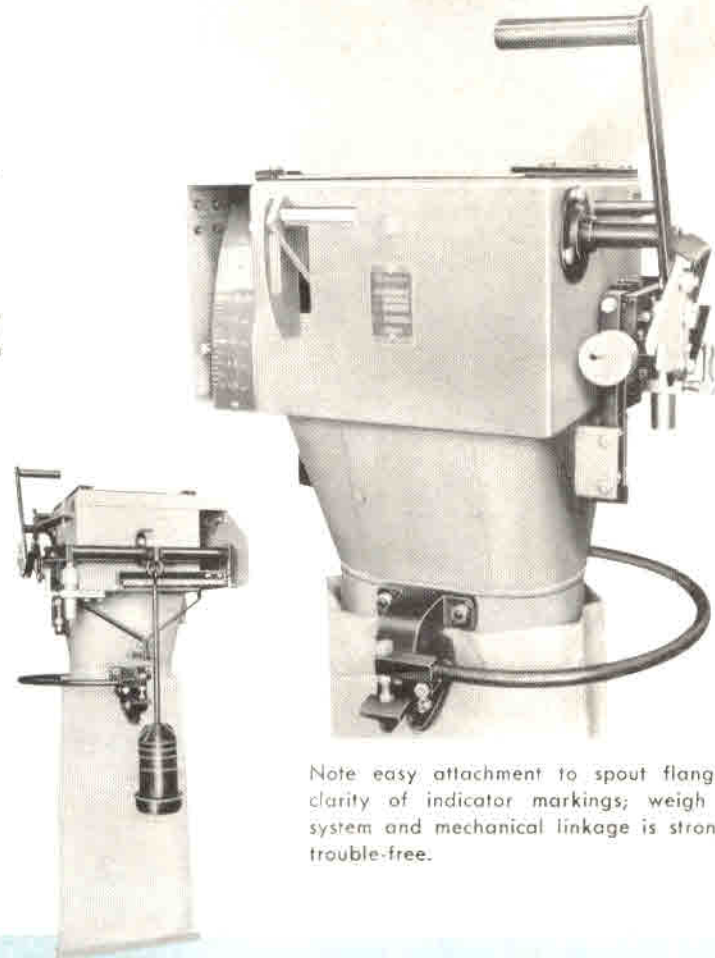

Note easy attachment to spout flange and clarity of indicator markings; weigh beam system and mechanical linkage is strong and trouble-free.

Operation

When the operator pulls down the gate handle, the radial inlet gate is completely opened, and held open by a sensitive trigger, causing material to flow from bin to bag. Feeding continues until proper weight is in the bag, at which point the radial inlet gate closes automatically and cuts off the feeding. An upward tap on the cam-grip bagholder bar releases the filled bag instantly and the next bag can be slipped around the spout underneath the bagholder cams. When fed on the stream, the machine can be left unattended because the cutoff is automatic.

BAG HOLDERS

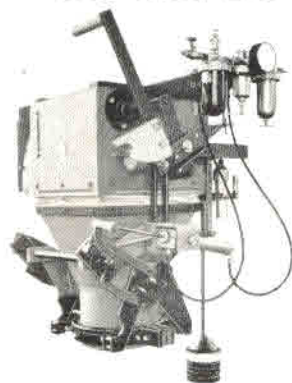

Automatic, Air Operated — foot-pedal control leaves both hands free to apply bags . . . gives increased bagging speed over manual types; toggle action locks clamps in either open or closed positions; rubber inserts (adjustable) in clamps seal bag around spout to keep dust in and prevent slippage. (Cam-grip bag-holder is standard).

Manual — same construction as "Automatic" except that bag-holder is actuated by an operating arm; a slight touch releases lock. Dust sleeves between chute and bag spout are provided with both types of bagholders.

QUICK-CHANGE SPOUTS



Six-inch Square Removable Spout; Double Cam-grips Used for Heavy Materials or Lined Bags.

To accommodate the use of several sizes of bags, the scale can be supplied with extra spouts which are easily attached or removed by two locking handles.

COUNTER • GATE SWITCH



Five-figure setback counter registers number of bags filled. Direct-connected to gate operating handle . . . registers one count each time bag is filled . . . can be returned to zero at the end of each run. Conveniently mounted at operator height.

When a belt, screw, or vibrating feeder is used, a gate switch (totally enclosed) actuated by the handle can be supplied to stop and start the feeder automatically.

STAINLESS STEEL

To meet sanitary, corrosive, or abrasive requirements, stainless steel of the correct specification can be supplied for those surfaces in contact with the material being weighed.

TEFLON LINING

Teflon lining can be supplied in bag spout, chute, and other contact surfaces when required to facilitate material flow.

PORTABLE FRAME

To serve several lines or spouts the G17 Bagging Scale can be supplied in a wheeled-frame, height-adjustable, to accommodate various bag lengths, spout-to-floor distances, etc. Rubber-tired wheels provide for easy portability.

FEEDERS

The G17 Bagging Scale can be supplied with a belt, screw, or vibrating feeder to suit the material being weighed.

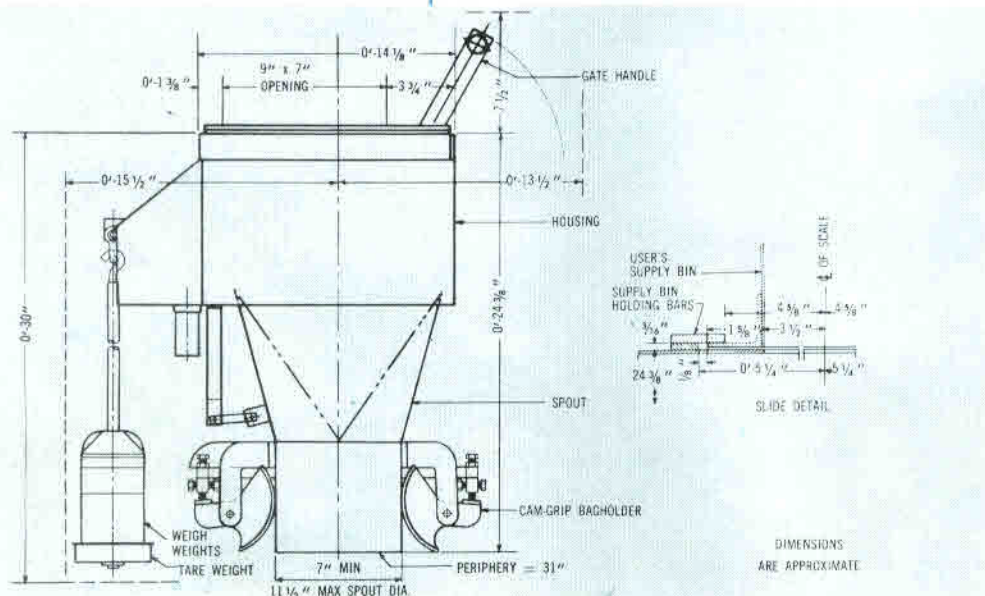

The G17 Bagging Scale conforms to U. S. Weights and Measures H-44 for your protection and is approved by Canadian Weights & Measures Section of Department of Trade and Commerce.

Shipping Weights — Domestic
[Approximate] — 200 lb.
Foreign
— 275 lb. gross.
— 200 lb. net.

Export Box Measures
[Approximate] — 31"x28"x32"

HOWE RICHARDSON SCALE COMPANY

EXECUTIVE OFFICES: CLIFTON, NEW JERSEY

**Howe
Richardson**

WINBORNS
WILLIAMSBURG, IOWA

UNITED STATES, AUSTRALIA, CANADA, ENGLAND, FRANCE, MEXICO, SOUTH AFRICA